

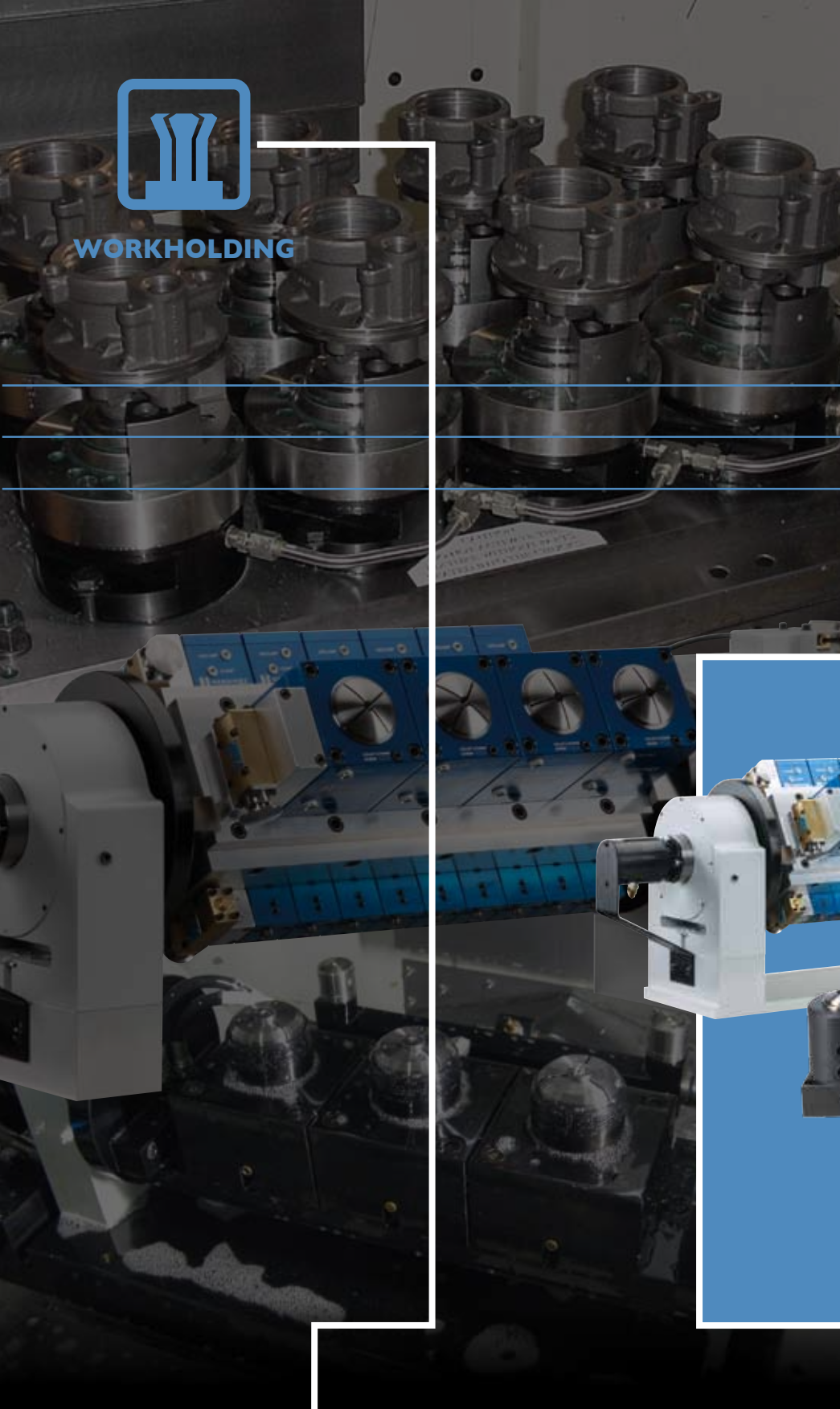

**WORKHOLDING**

Collet Blocks



TURNING MILLING GRINDING WORKHOLDING ROTARY

[www.hardinge.com](http://www.hardinge.com)



# Part Setup Reduction

Hardinge has several options for holding single or multiple parts on your machine table, in trunnions or on towers ...

- Diverse group of products to fit your unique requirement
- Modular components for flexible configurations in horizontal or vertical setups
- Reduce setup and increase productivity using multiple part fixturing
- Low profile models for a large work envelope
- All models use standard collets – 1C, 3C, 5C, 16C, 3J, 22J, 35J, 42mm, 65mm
- Select models can use step chucks and expanding collets
- Range of products to fit your budget and your part size
- Complete turnkey services available with quick turnaround

## TABLE OF CONTENTS

1C and 3C Collet Blocks .....	9
5C Collet Blocks	
Tri-Grip Dead-Length .....	5
Fail-Safe Pneumatic Pull-back.....	6
High-Pressure Hydraulic.....	7
Low-Pressure Pneumatic.....	8
Dead-Length Pneumatic	
or Hydraulic.....	9
Pull-back Threaded-nose .....	10
16C Collet Blocks	
High-Pressure Hydraulic.....	7
Dead-Length Pneumatic	
or Hydraulic.....	9
A2-5, 16C Pneumatic	
or Hydraulic.....	10-11
3J, 22J and 35J Collet Blocks.....	7
42 and 65mm Collet Blocks .....	4
Custom-manufacturing and	
Turnkey Service.....	12
Sample Hydraulic Configurations....	13
Hydraulic Accessories .....	14-15
Multiple Collet Block	
Configurations .....	16
Pneumatic Accessories.....	17
Sample Pneumatic Configuration ....	17
Collets .....	18
Frequently Asked Questions.....	19



*FlexC™ Collet Blocks are quick-change with high grip force—details on page 4*



*1C and 3C Collet Blocks are ideal for machining small parts such as medical devices, fuel injectors and electronic components. —details on page 9*



*Tri-Grip 5C Hydraulic Collet Blocks are a popular, inexpensive solution to modular fixturing. —details on page 5*



*Fail-safe 5C Pneumatic Collet Blocks use collets, expanding collets or step chucks to grip a variety of parts. —details on page 6*



*High-pressure Collet Blocks available in 5C, 16C, 3J, 22J and 35J collet sizes —details on page 7*

# Important to Regulate for Safety!

## Maximum Recommended Input Pressure

**WARNING: SAFE INPUT PRESSURE SHOULD BE REGULATED FOR THE COLLET, NOT THE CAPABILITY OF THE COLLET BLOCK. DO NOT EXCEED THE RECOMMENDED INPUT PRESSURE LISTED BELOW—DAMAGE TO THE COLLET WILL OCCUR AND BODILY HARM MAY RESULT FROM THE COLLET COMING LOOSE.**

DRAW FORCE RATIO x INPUT PRESSURE = DRAW FORCE OUTPUT (not to exceed max collet safety output force) x COLLET GRIP FORCE RATIO = THEORETICAL COLLET GRIP FORCE

COLLET BLOCK PART NUMBER	COLLET SIZE	MAX COLLET GRIPPING DIAMETER	DRAW FORCE RATIO	MAX UNIT INPUT AIR PRESSURE	MAX UNIT INPUT HYD PRESSURE	DO NOT EXCEED		COLLET GRIP FORCE RATIO	THEORETICAL COLLET GRIP FORCE @ OUTPUT DRAW FORCE
						MAX INPUT AIR PRESSURE	MAX INPUT HYD PRESSURE		
7799-00-00-420010	42mm	1.653" (42.00)	11.3:1		2000 PSI		2000 PSI	1.7:1	38420#
7799-00-00-650010	65mm	2.559" (65.00)	14.1:1		2000 PSI		2000 PSI	1.7:1	47940#
7799-00-00-000088	5C (3X)	1 1/16" (26.99)	1.1:1		5000 PSI		2727 PSI	3.4:1	10200#
CB-0007901-A	5C <sup>1,2</sup>	1 1/16" (26.99)	N/A	75 PSI		75 PSI		3.4:1	5984#
7799-00-00-000095	5C	1 1/16" (26.99)	1.9:1		5000 PSI		1579 PSI	3.4:1	10200#
7799-00-00-000094	16C	1 5/8" (41.28)	1.9:1		5000 PSI		3684 PSI	3.4:1	23800#
7799-00-00-000093	3J	1 3/4" (44.45)	1.9:1		5000 PSI		3158 PSI	4.9:1	29400#
7799-00-00-000092	22J	2 1/4" (57.15)	1.9:1		5000 PSI		5000 PSI	4.9:1	46550#
7799-00-00-000091	35J	3 1/2" (88.90)	1.8:1		5000 PSI		5000 PSI	4.9:1	44100#
7799-00-00-000099	5C <sup>2</sup>	1 1/16" (26.99)	7.5:1	150 PSI		150 PSI		3.4:1	3825#
7799-00-00-000098	5C <sup>2</sup>	1 1/16" (26.99)	7.5:1	150 PSI		150 PSI		3.4:1	3825#
7799-00-00-000090	1C	1/4" (6.35)	.73:1	250 PSI	750 PSI	250 PSI	750 PSI	1.7:1	311#/932#
7799-00-00-000089	3C	1/2" (12.70)	1.2:1	250 PSI	750 PSI	250 PSI	750 PSI	2.7:1	810#/2430#
7799-00-00-000097	5C	1 1/16" (26.99)	7.5:1	150 PSI	750 PSI	150 PSI	400 PSI	3.4:1	3825#/10200#
7799-00-00-000096	16C	1 5/8" (41.28)	5.8:1	250 PSI	2000 PSI	250 PSI	1207 PSI	3.4:1	4930#/23800#
7799-00-00-000087	5C <sup>1,2</sup>	1 1/16" (26.99)	7.5:1	150 PSI	750 PSI	150 PSI	400 PSI	3.4:1	3825#/10200#
7799-00-00-000086	16C <sup>1,2</sup>	1 5/8" (41.28)	23:1	250 PSI	400 PSI	250 PSI	304 PSI	3.4:1	19550#/23800#
2185-00-00-	16C <sup>1</sup>	1 5/8" (41.28)	22:1	100 PSI		100 PSI		3.4:1	7514#

1 - Step Chucks can be used on these models.

millimeters in parentheses ( )

2 - Sure-Grip® Expanding Collets can be used on these pull-back models. Do NOT exceed manufacturer recommended draw bar force.

## Which style collet block is best for me? Do I need pneumatic or hydraulic operation?

The part diameter or range of parts that you are working with will indicate the collet size required. The required gripping force will be determined by the part size and the machining process that you will perform. Higher gripping forces will be needed for heavy rotation, tapping, threading or off-center work. Hardinge will help you determine what size collet block you need, whether you need a high-force or low-force collet block, and if you need hydraulic or pneumatic operation. Clamp only what is required – operate at the pressure required for each individual machining application. Equivalent collet gripping forces at maximum recommended draw bar force output are indicated above, along with the round collet maximum gripping diameter. Hex, square and custom-shape collets are available. Hardinge Sure-Grip® Expanding Collets<sup>2</sup> can be used in the 5C and 16C pull-back collet blocks for internal gripping. Step Chucks<sup>1</sup> provide gripping for custom shapes or larger diameters up to 6" (152.4mm) on select models.

## Pneumatically-operated Collet Blocks for light-to-medium machining operations

Most shops prefer to use air-operated collet blocks simply because the shop air is readily available and easy to connect without the need for many plumbing accessories. A single collet block or a row of collet blocks can be directly connected to an air line inside of the machine when safely positioned so as not to interfere with any movement during the machining process. One control valve will open all collets or arrange individual control valves for each section of collet blocks that you want to open independently. If shop air is not available a small compressor will do the job. Filtered air is always recommended. Collets will open if loss of air occurs – choose the Hardinge fail-safe 5C model for "fail-safe" operation. Refer to the typical pneumatic diagram on page 17. Connector bushings and control valves are shown on page 17.

## Hydraulically-operated Collet Blocks for heavier machining operations and off-center work

Hydraulic systems provide a higher clamping force which you can see from the chart above. For larger gripping diameters the 3J, 22J, 35J and FlexC units are available as hydraulic units. Hardinge offers an inexpensive air over hydraulic pump and other hydraulic components for a compact setup. Refer to the hydraulic diagrams and accessories on pages 13-15. Complete turnkey services are available.

# FlexC™ Dead-Length Collet Blocks

High-Pressure 42 and 65mm Hydraulic

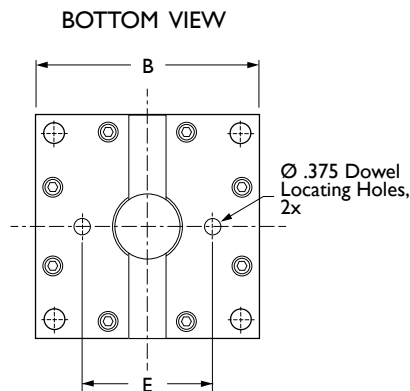
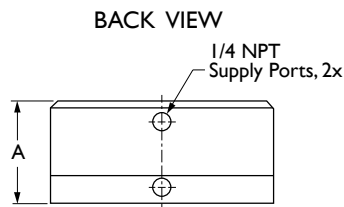
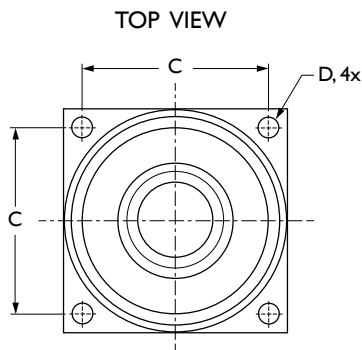

FlexC Collet Blocks are ideal for either horizontal or vertical machining center applications. Their low profile provides maximum tool clearance with the ability to machine taller workpieces. With a maximum working pressure of 2,000 PSI and a draw tube force of 11.3 (42) and 14.1 (65) times the applied pressure, these units provide superior part rigidity with no pushback or rotation during heavy machining. Double-acting, dead-length operation assures maintained height from part-to-part. Units mount from the top with a thru-hole base design.

The FlexC collet blocks are the lowest profile models available. Collet blocks accept round smooth, round serrated, hex, square and emergency collets to accept parts of all shapes. FlexC vulcanized collets have a flexible gripping range of  $\pm 0.020$ " (.5mm) above and below its nominal size to accept workpiece inconsistency. Collets change out in seconds using the quick-change compression wrench.

See page 16 for sample multi-block configurations. Collets and Collet wrench sold separately.

- 2.75" (42mm) or 3.172" (65mm) low profile (69.85 or 80.56mm)
- Dead-length part length control
- Double-acting cylinders—pressure-to-open, pressure-to-close
- Uses 42 or 65mm FlexC vulcanized collets
- Modular units for custom configurations
- Hydraulic operation



Part Number	Collet Type	Max Unit Input Press. Hyd	Draw Force	DIMENSIONS					Port Size
				A	B	C	D	E	
7799-00-00-420010 (65502H)	42mm FlexC	2000PSI	11.3 x Line	2.75 (69.85)	6.00 (152.40)	5.00 (127.00)	1/2 SHCS —	3.50 (88.90)	1/4 NPT
7799-00-00-650010 (65501H)	65mm FlexC	2000PSI	14.1 x Line	3.172 (80.56)	7.00 (177.80)	6.00 (152.40)	1/2 SHCS —	4.50 (114.30)	1/4 NPT

Installation instructions can be found online at [www.shophardinge.com](http://www.shophardinge.com)

Millimeters in parentheses ( )

# Tri-Grip Dead-Length Collet Blocks

## High-Pressure 5C Hydraulic

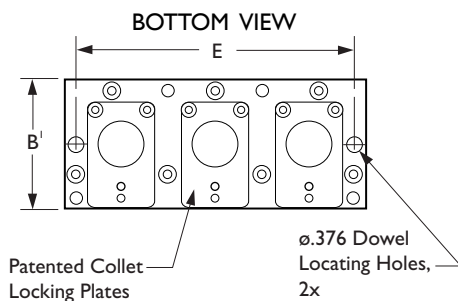
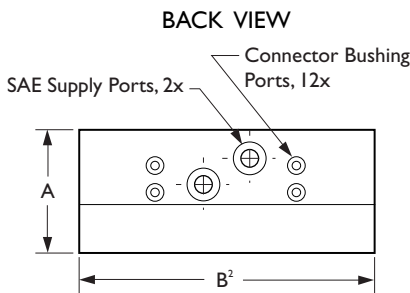
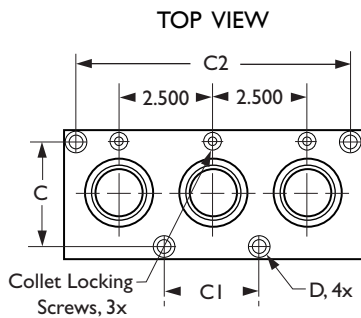

Tri-Grip Collet Blocks are ideal for either horizontal or vertical machining center applications. Their compact design, simplified plumbing (three closers in one body) and patented "accessible-from-the-top" collet locking screw all lead to faster setups and infinite collet or part orientation. With a maximum input pressure of 5,000 PSI and a draw tube force of 1.1 times the applied pressure, these units can provide ample grip for all of your workholding needs. Double-acting, dead-length operation assures maintained height from part-to-part. These models can be combined in multiple configurations on a subplate or tower with the use of connector bushings (page 14) to eliminate external plumbing between units. Collet locking screws are located on the top of the unit for easy access and to allow side-by-side multiple unit configurations. A patented collet locking plate locates the collet with infinite collet or part orientation and will accommodate timed or synchronized parts with orientation independent of the keyway. Unit mounts from the top with a thru-hole base design.

See page 16 for sample multi-block configurations. Collet wrench included. Collets sold separately.

- 3.5 x 8" footprint (88.9 x 203.2mm)
- Dead-length part length control
- Double-acting cylinders—pressure-to-open, pressure-to-close
- Uses (3) standard 5C collets
- Modular units for custom configurations
- Hydraulic operation

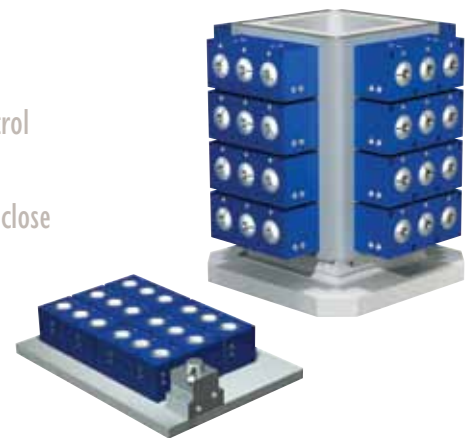

Part Number (Model Number)	Collet Type	Max Unit Input Press. Hyd	Draw Force	DIMENSIONS							
				A	B <sup>1</sup>	B <sup>2</sup>	C	C <sup>1</sup>	C <sup>2</sup>	D	E
7799-00-00-000088 (65401H)	5C (3x)	5000PSI	1.1 x Line	3.31 (84.07)	3.5 x 8.0 (88.9 x 203.2)		2.876 (73.05)	2.500 (63.50)	7.376 (187.35)	5/16 SHCS	7.376 (187.35)

Installation instructions can be found online at [www.shophardinge.com](http://www.shophardinge.com)

Note: Connector bushings add space between units. Tri-Grip units will have a 3.75" and/or 8.25" on-center dimensions when using connector bushings.

Millimeters in parentheses ( )

# Fail-Safe Collet Block

## 5C Pneumatic Pull-back

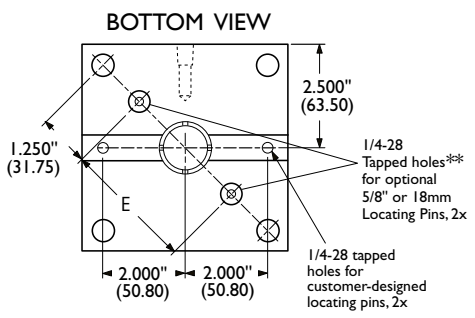
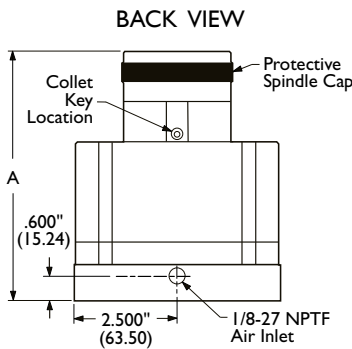
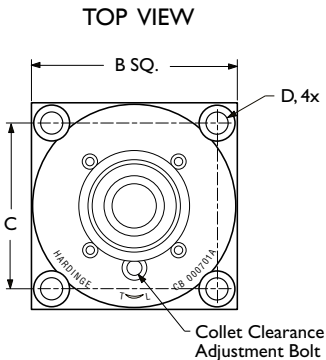

The Hardinge 5C ( $2\frac{3}{16}$ -10) threaded-nose Collet Block accepts an entire array of workholding products. Standard 5C collets, collet stops, Dead-Length<sup>®</sup> collets, step chucks, Sure-Grip<sup>®</sup> expanding collets and manual chucks will thread onto the spindle nose for increased capabilities. Collets and other tooling sold separately.

Air is required during setup whether using a single collet block or a subplate full of collet blocks. The fail-safe design does not require air during the cutting process. This results in maintained concentricity without downtime or waste if loss of air should occur. The Hardinge base design is open, allowing coolant and chips to be blown out rather than building up. This eliminates the need to tear down and clean out the unit.

Modular units can be used vertically or horizontally for machining or assembly operations.



$2\frac{3}{16}$ -10 threaded-nose accepts collets, expanding collets (shown), step chucks and manual chucks.

- Hardinge  $2\frac{3}{16}$ -10 threaded-nose accepts an array of 5C tooling
- Can mount direct to T-slots
- Fail-safe design
- Air-to-open, spring-to-close
- Pneumatic operation
- All-steel construction

Part Number	Collet Type	Max Unit Input Press. Air	Draw Force	DIMENSIONS				
				A	B	C	D	E
CB 0007901-A	5C	75PSI*	1760 lbs. 7829N	6.03 (153.16)	5.00 (127.00)	4.00 (101.6)	1/2-13	3.157 (80.18)

Installation instructions available online at [www.shophardinge.com](http://www.shophardinge.com)

\* Recommended operating pressure

\*\* Locating Pins sold separately. 5/8" diameter PN: CI 000199011, 18mm dia. PN: CI 000199018MM

Millimeters in parentheses ( )

# High-Pressure Dead-Length Collet Blocks

5C, 16C, 3J, 22J and 35J Hydraulic

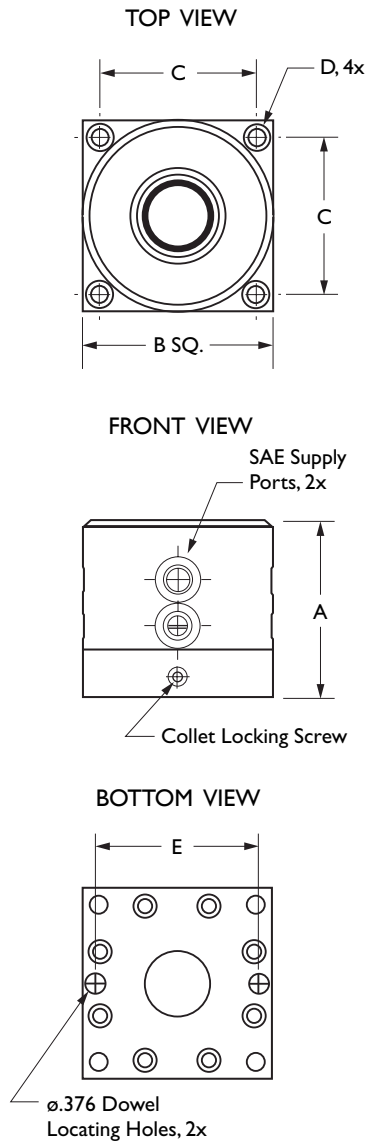

High-pressure hydraulic collet blocks feature operating pressures to 5,000 PSI. All models feature Dead-length design to maintain a consistent length from part-to-part. Precision-bored orientation holes are located in the base for thru-mounting. Connect multiple units with connector bushings (page 14) for continuous internal plumbing between units.

Holding forces generated by the draw tube are 1.9 times the line pressure applied so extremely high clamping forces can be generated. Thru-hole design is standard.

**Collet wrench included.**  
**Collets sold separately.**

- Operating pressure up to 5,000 psi
- All-steel construction
- Dead-Length part length control
- Double-acting cylinders—pressure-to-open, pressure-to-close
- Hydraulic operation
- Use standard collets
- Mounts direct to T-slots

Part Number (Model Number)	Collet Type	Max Unit Input Press. Hyd	Draw Force	DIMENSIONS					Port Size
				A	B	C	D	E	
7799-00-00-000095 (65301H)	5C	5000 PSI	1.9x Line	3.25 (82.55)	3.50 (88.90)	2.875 (73.02)	5/16 SHCS	3.000 (76.20)	SAE 4
7799-00-00-000094 (65302H)	16C	5000 PSI	1.9x Line	4.31 (109.47)	4.00 (101.60)	3.250 (82.55)	3/8 SHCS	3.000 (76.20)	SAE 4
7799-00-00-000093 (65303H)	3J	5000 PSI	1.9x Line	3.75 (95.25)	4.00 (101.60)	3.250 (82.55)	3/8 SHCS	3.000 (76.20)	SAE 4
7799-00-00-000092 (65305H)	22J	5000 PSI	1.8x Line	4.06 (103.12)	5.50 (139.70)	4.500 (114.30)	1/2 SHCS	4.500 (114.30)	SAE 6
7799-00-00-000091 (65304H)	35J	5000 PSI	1.9x Line	5.06 (128.52)	7.00 (177.80)	5.750 (146.05)	1/2 SHCS	6.000 (152.40)	SAE 6

Installation instructions available online at [www.shopharding.com](http://www.shopharding.com)

Note: Connector bushings add space between units. Units will have on-center dimensions accordingly when using connector bushings - 5C 3.750"; 16C 4.250"; 3J 4.250"; 22J 5.625"; 35J 7.125".

Millimeters in parentheses ( )

# Low-Pressure Pneumatic Collet Blocks

## 5C Pneumatic Pull-Back



- Pull-back design
- Double-acting cylinders—pressure-to-open, pressure-to-close
- Pneumatic operation
- Use standard 5C collets
- Flange-style model mounts directly to T-slots

These rugged units are made from solid aircraft aluminum. The force generated by the draw tube is 7.5 times the line pressure applied. The units allow working pressures to 150 PSI. Thru-hole design is standard.

Collet wrench included. Collets sold separately.

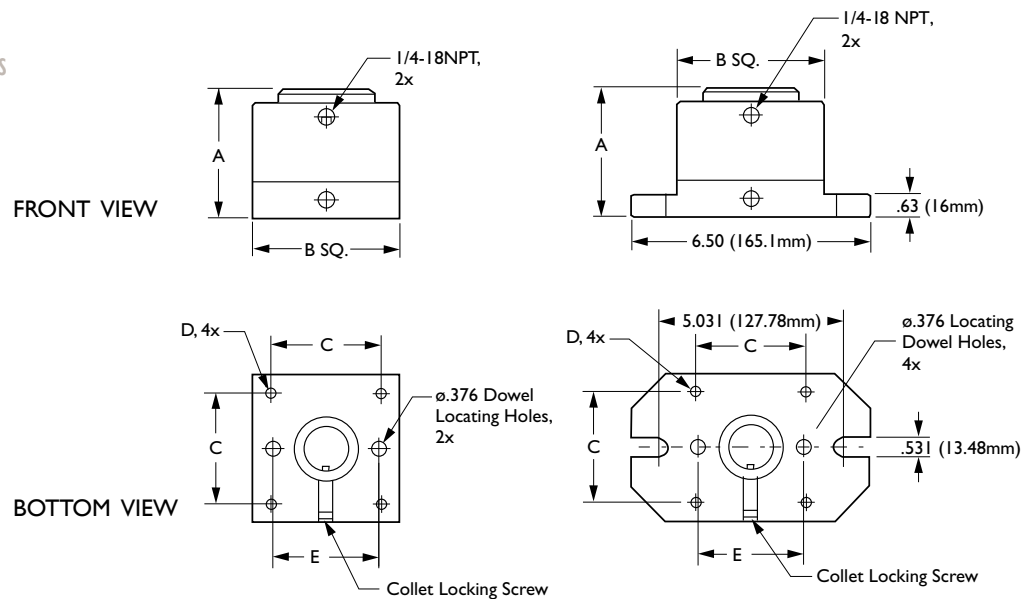

Part Number (Model Number)	Collet Type	Max Unit Input Press. Air	DIMENSIONS				
			A	B	C	D	E
7799-00-00-000099 (65101H)	5C	150PSI	3.50 (88.90)	4.00 (101.60)	3.00 (76.20)	3/8-24	2.875 (73.02)
7799-00-00-000098 (65102H) flange style	5C	150PSI	3.50 (88.90)	4.00 (101.60)	3.00 (76.20)	3/8-24	2.875 (73.02)

Installation instructions available online at [www.shophardinge.com](http://www.shophardinge.com)

Millimeters in parentheses ( )

# Dead-Length Collet Blocks

## 1C, 3C, 5C and 16C Pneumatic or Hydraulic

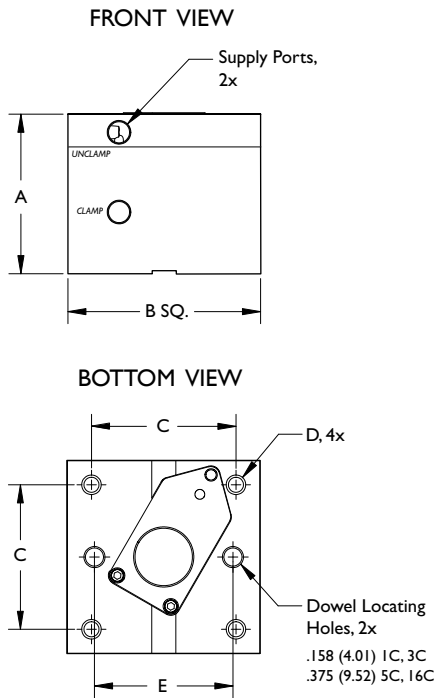

Dead-length design assures part length consistency from part-to-part. This family of collet blocks can be used on pneumatic service of 250 PSI (150/5C), or hydraulic service of 750 PSI (2000/16C). The collet blocks are machined from aircraft quality aluminum for long life. Forces generated by the draw tube range from .73 (1C) to 7.5 (5C) times the line pressure applied. Combine units for multiple part setups. Connector bushings (page 14 or 17) will eliminate the external plumbing between units. Patented collet locking screws are located on the top of the unit for easy access and to allow side-by-side multiple unit configurations. Thru-hole design is standard.

See page 16 for sample multi-block configurations. Collet wrench included. Collets sold separately.

- Dead-Length part length control
- Double-acting cylinders— pressure-to-open, pressure-to-close
- Pneumatic or hydraulic operation
- Use standard 1C, 3C, 5C or 16C collets

Part Number	Collet Type	Max Unit Input Press. Hyd	Max Unit Input Press. Air	DIMENSIONS					Port Size
				A	B	C	D	E	
7799-00-00-000090 (65106H)	1C	250PSI	750PSI	1.438 (36.52)	1.75 (44.45)	1.375 (34.92)	#10-24	1.125 (28.57)	1/8-27 NPT
7799-00-00-000089 (65105H)	3C	250PSI	750PSI	2.74 (69.59)	2.50 (63.50)	2.00 (50.8)	1/4-20	2.00 (50.8)	1/8-27 NPT
7799-00-00-000097 (65205H)	5C	150PSI	750PSI	3.31 (84.07)	4.00 (101.60)	3.00 (76.20)	3/8-16	2.875 (73.02)	1/4-18 NPT
7799-00-00-000096 (65206H)	16C	250PSI	2000PSI	4.25 (107.95)	4.00 (101.60)	3.00 (76.20)	3/8-16	2.875 (73.02)	1/4-18 NPT

Installation instructions available online at [www.shophardinge.com](http://www.shophardinge.com)

Note: Connector bushings add space between units. Units will have on-center dimensions accordingly when using connector bushings – 1C 1.812"; 3C 2.562"; 5C 4.062"; 16C 4.062".

Millimeters in parentheses ( )

# Pull-Back Collet Blocks

5C and A2-5 16C Pneumatic or Hydraulic



- Pull-back design
- Double-acting cylinders—pressure-to-open, pressure-to-close
- Pneumatic or hydraulic operation
- Use standard 5C or 16C tooling



5C BOTTOM VIEW

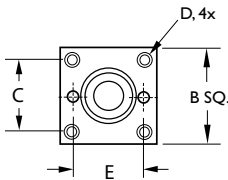

5C FRONT VIEW

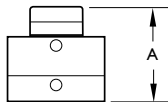

16C TOP VIEW

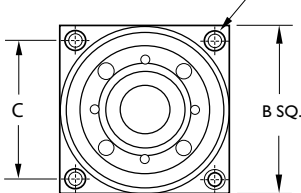

16C FRONT VIEW

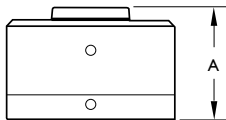

16C BOTTOM VIEW

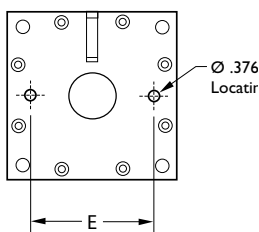

## 5C Pneumatic/Hydraulic Collet Block

This versatile 5C threaded-nose model uses standard 5C collets, expanding collets or step chucks to accommodate parts up to 6" (152.4mm) in diameter. This heavy-duty steel unit is designed for use with pneumatic service to 250 PSI or hydraulic service to 750 PSI. Draw tube force is 7.5 times the line pressure which maximizes the gripping force available from this compact unit. Combine units for multiple part setups. Connector bushings (page 14 or 17) will eliminate the external plumbing between units.

## 16C Pneumatic/Hydraulic Collet Block

The 16C model features an A2-5 spindle nose that accepts 16C collets, expanding collets and 16C step chucks & closers for parts up to 6" (125.4mm) in diameter. Applied line pressure is multiplied 23 times the inlet pressure, generating high draw tube forces. Maximum working pressure is 250 PSI in pneumatic service or 400 PSI in hydraulic service. The units are machined from aircraft quality aluminum and feature hardened steel bushings for long-lasting, trouble-free service.

See page 16 for sample multi-block configurations. Collet wrench included. Collets sold separately.

Part Number (Model Number)	Collet Type	DIMENSIONS				
		A	B	C	D	E
7799-00-00-000087 (65203-H)	5C	3.90 (99.18)	4.00 (101.60)	3.00 (76.20)	3/8-24 SHCS	2.875 (73.02)
7799-00-00-000086 (65204-H)	16C	4.625 (117.47)	6.938 (176.22)	5.750 (146.05)	1/2 SHCS	5.000 (127.00)

Installation instructions available online at [www.shophardinge.com](http://www.shophardinge.com)

Millimeters in parentheses ( )

Note: Connector bushings add space between units. Units will have on-center dimensions accordingly when using connector bushings - 5C 4.062"; 16C n/a. Connector bushings may not be able to be used with larger diameter parts being held in step chucks.

# Dead-Length® Collet Blocks

A2-5, I6C Pneumatic

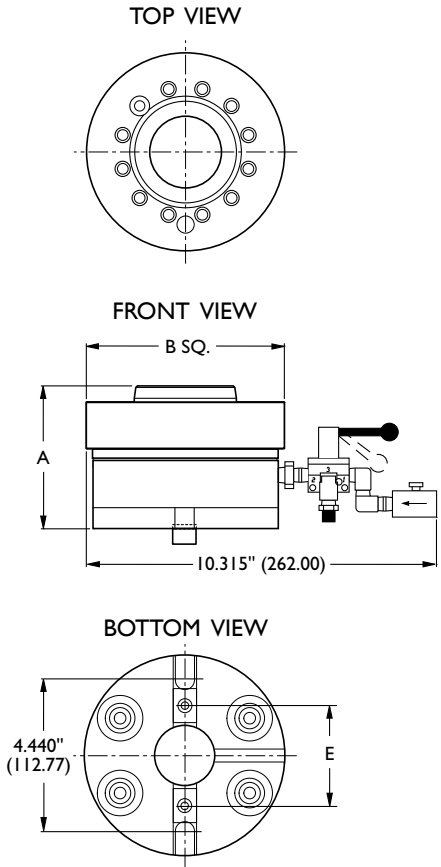

16C Collet Blocks can be mounted on any milling machine in a production environment, as well as for tool room applications. It accepts all standard 16C round, hexagon, square and special-shape collets and step chucks. This is a precision length control device – the collet does not move. The collet block is pneumatically actuated with a manually-operated valve. The A2-5 spindle nose accepts closers for step chuck work up to 6" in diameter. A special collet stop (shown below) is required. Hardinge's standard collet stops will not work due to interferences. Use individually or group units on a subplate for multiple part processing.

**Note:** Standard Dead-Length Collets and Sure-Grip® Expanding Collets do not work on this device because the spindle moves and the collet is stationary.

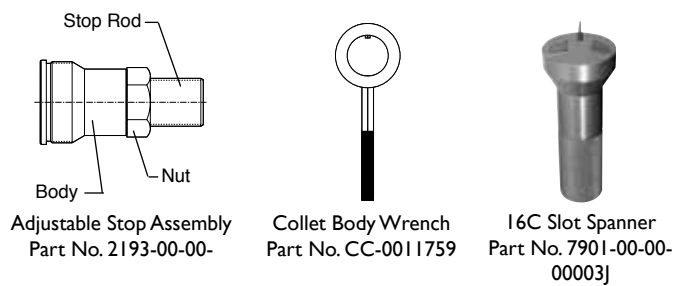

- Dead-Length part length control
- Spring-to-open, pressure-to-close
- Pneumatic operation
- Use standard A2-5, I6C tooling
- Mounts directly to T-slots

Part Number	Collet Type	Max Unit Input Press. Air	Max Draw Force	DIMENSIONS					Port Size
				A	B	C	D	E	
2185-00-00-	I6C	250PSI	750#	4.53 (115.06)	6.28 (159.51)	4.44 (112.77)	—	2.94 (74.67)	1/8- NPT

Installation instructions available online at [www.shophardinge.com](http://www.shophardinge.com)

Millimeters in parentheses ( )

# Custom Applications & Turnkey Service

Fixture plates, tombstones and trunnions



- Pneumatic or hydraulic operations
- Aircraft aluminum or heavy-duty steel
- Dead-length or pull-back clamping
- Part length control
- Double-acting cylinders (pressure-to-open, pressure-to-close) or fail-safe 5C Pneumatic system
- Use standard collets—1C, 3C, 5C, 16C, 3J, 22J, 35J, 42mm, 65mm
- Special-shape collets and larger part gripping
- Range of products to fit your budget
- Quick turnaround of quote and model drawing



48-collet tombstone tower fixture with (16) high-pressure hydraulic Tri-Grip Collet Blocks shown. Connector bushings are used between each group of the four blocks to keep all plumbing internal.



Hardinge® PT5C2 Rotary Indexer with plate trunnion shown. Ten 1C Collet Blocks are mounted on the plate.

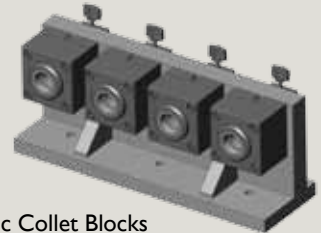

Pneumatic Collet Blocks with angled fixture plate and four separate controls.



Custom hydraulic pallet application for through-hole work-piece with adjustable stop plate for part length control. Vertical accumulator with vertical manifold mounting block.



Quick disconnect handle and disconnect manifold with built-in check valve.

# Sample Hydraulic Configurations

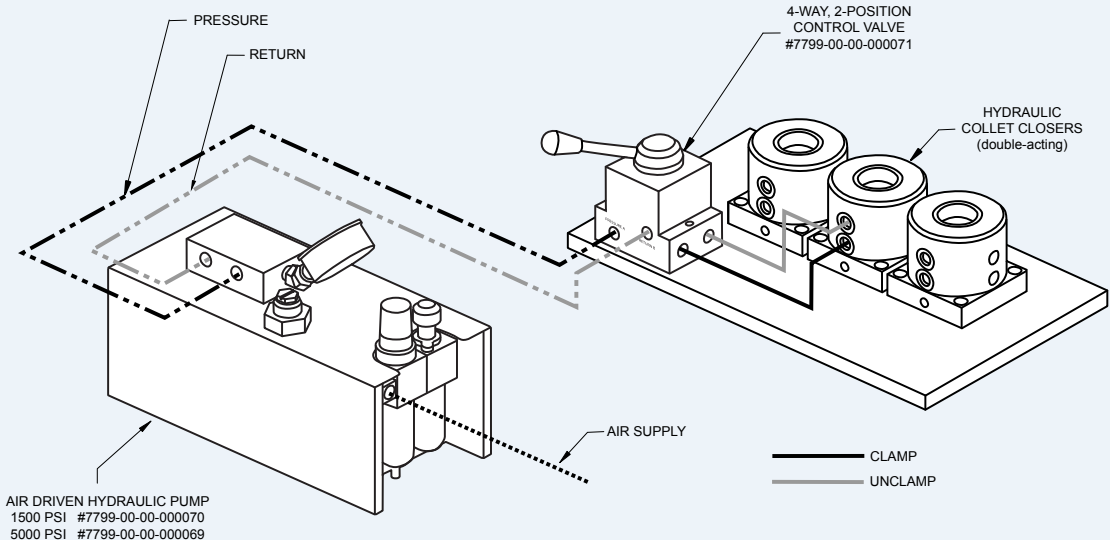

## Example of a typical hydraulic configuration

Components include a pump, control valve and three hydraulic collet blocks supplied by Hardinge mounted on a customer machined fixture plate. (Schematic shown in clamp position)

Installation instructions available online at [www.shophardinge.com](http://www.shophardinge.com)

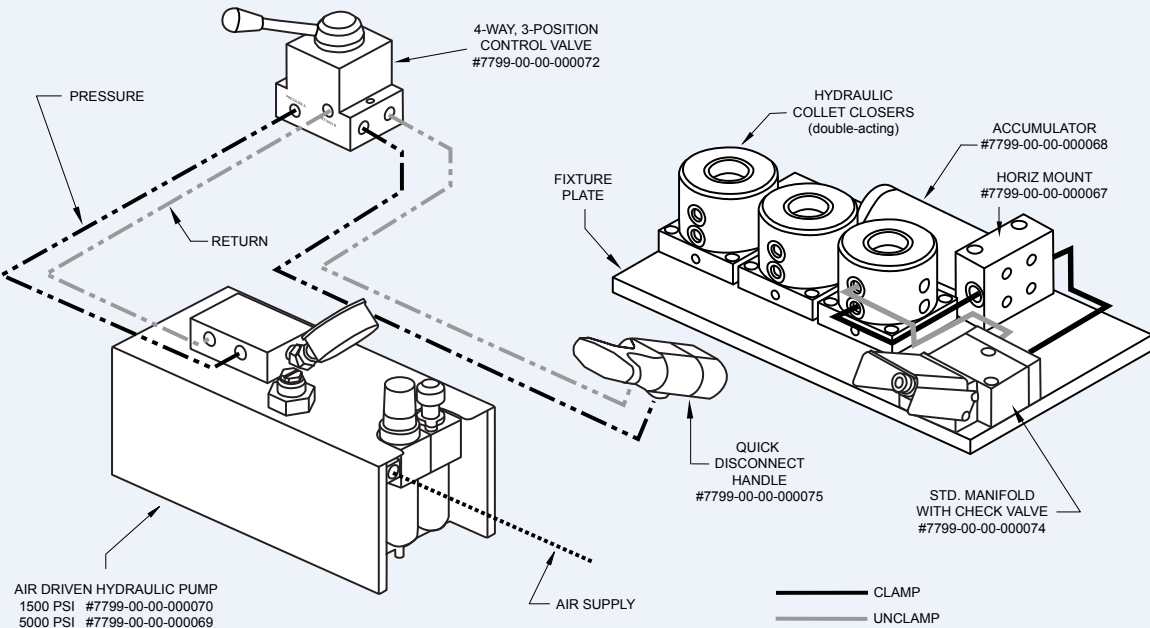

## Example of a quick-disconnect hydraulic configuration

Components include a pump, control valve, accumulator with mount, quick-disconnect handle, manifold with check valve and three hydraulic collet blocks supplied by Hardinge on a customer-machined fixture plate. The control valve should mount outside of the machine with the pump or on the outside wall of the machine. The quick disconnect with check valve allows you to remove the hydraulics while in the clamp mode – ideal for preloading pallets. An accumulator is required when using the quick disconnect product. (Schematic shown in the clamp position)

Installation instructions available online at [www.shophardinge.com](http://www.shophardinge.com)

# Hydraulic Accessories

## Connector Bushings and Quick-Disconnect System

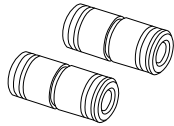

### Connector Bushings for Internal Plumbing

Connector bushings can be used to connect multiple collet blocks to operate on a single control valve. Simply remove the two plugs on the pressure ports of the collet block and insert two connector bushings for each side of the collet block that you would like to connect to another collet block. See illustration on page 16. Connector bushings allow you to keep all plumbing internal. Not all models shown in this brochure use connector bushings - see chart below.

Description	For use with	Part Number	(Model No.)
Connector Bushing (1)	5C, 16C, 3J, 22J, 35J and Tri-Grip (excludes models on pages 4, 6, 8, 11)	7799-00-00-000078	(02-1082)
Connector Bushing (1)	1C collet blocks	7799-00-00-000077	(65-0250)
Connector Bushing (1)	3C collet blocks	7799-00-00-000076	(65-0230)

Installation instructions available online at [www.shopharding.com](http://www.shopharding.com)

### Quick-Disconnect Handle and Disconnect Manifolds



The quick-disconnect handle, standard manifold and manifold with check valve are used to conveniently and quickly connect and disconnect both hydraulic hoses of a double-acting pallet system. The quick-disconnect handle is complete with two female fittings to plug into the standard manifold receiver that will mount to your pallet. The quick-disconnect handle will remain connected to maintain a clamp position when using the standard manifold. Choose the manifold with a built-in check valve when you would like to hold the clamp position when removing the disconnect handle. This feature is convenient for preloading pallets and maintaining clamped parts during load and unload. A 3-position, 4-way control valve is required to operate the manifold with check valve. Maximum pressure is 5000 PSI with a 2500 PSI minimum latching pressure. An accumulator is required with the quick-disconnect system. Control valves, pumps and accumulators sold separately.

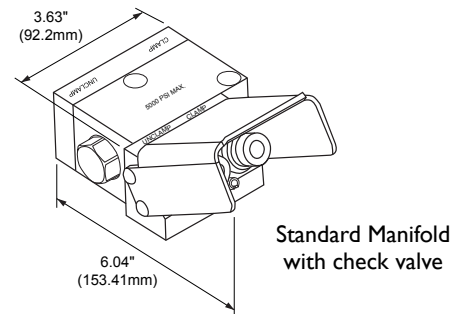
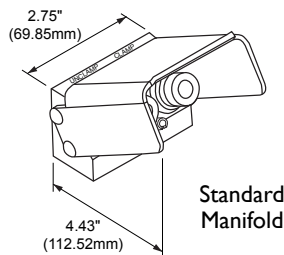
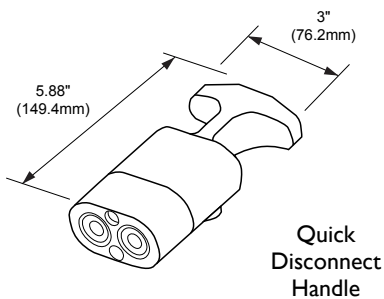

Description	For use with	Part Number	(Model No.)
Quick-Disconnect Handle	Hydraulic fixturing (2000-5000psi)	7799-00-00-000075	(65-0074)
Standard Manifold	Disconnect Handle for custom fixturing	7799-00-00-000073	(65-0075)
Standard Manifold with built-in Check Valve	Disconnect Handle for pallet systems	7799-00-00-000074	(65-0076)

Installation instructions available online at [www.shopharding.com](http://www.shopharding.com)

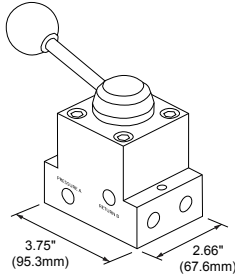

### Hydraulic Control Valves

To operate hydraulic collet blocks with a standard disconnect manifold or without quick disconnect, Hardinge offers a 2-position, 4-way control valve for simple clamp and unclamp operation. The 3-position, 4-way directional control valve is used for operating collet blocks with a quick-disconnect manifold and built-in check valve. Control valves have four 1/4" NPT ports and two mounting holes. Purchase additional control valves to have collet blocks open independent from others. Pumps and accumulators sold separately.

Description	For use with	Part Number	(Model No.)
3-Position, 4-way Control Valve	Pumps listed below	7799-00-00-000072	(65-0032)
2-Position, 4-way Control Valve	Pumps listed below	7799-00-00-000071	(65-0029)

Installation instructions available online at [www.shophardinge.com](http://www.shophardinge.com)

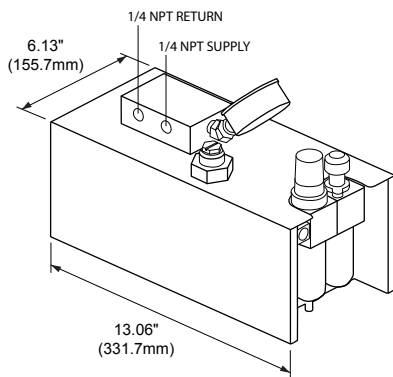

### Air-over-Hydraulic Pump

Hardinge offers a self-contained, air-operated hydraulic pump in a small footprint. Choose from a 1500 PSI or a 5000 PSI model. A built-in regulator provides adjustment down to the required hydraulic pressure for your machining application. Recommended air pressure is 110 PSI maximum, 40 PSI minimum. This self-contained pump will locate outside of the machine. An accumulator is required for systems using the quick-disconnect feature. Control valves and accumulators sold separately.

Description	Part Number	(Model No.)
1500psi/max Air-operated self-contained Pump	7799-00-00-000070	(65-0033)
5000psi/max Air-operated self-contained Pump	7799-00-00-000069	(65-0078)

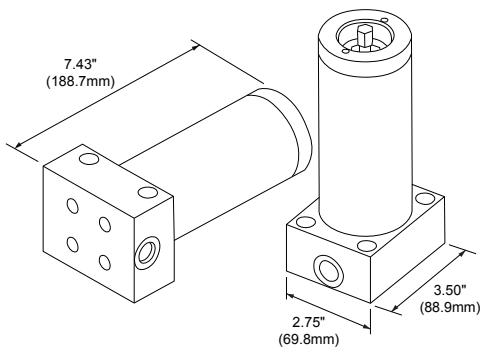

### Accumulators

Accumulators are a backup reservoir that will maintain pressure if a leak should occur. The unit is precharged to 1500 PSI. Manifold mounts are available to mount the accumulator either vertically or horizontally depending on the collet block configuration and clearances required. Units have two SAE-6 ports and two mounting holes for 5/16" SHCS. An accumulator is required for systems using the quick-disconnect feature. Pumps and control valves sold separately.

Description	For use with	Part Number	(Model No.)
5000 PSI Accumulator	All Hydraulic collet blocks	7799-00-00-000068	(65-0140)
Manifold Mounting Block	Horizontal Mount Accumulator	7799-00-00-000067	(65-0117-1)
Manifold Mounting Block	Vertical Mount Accumulator	7799-00-00-000066	(65-0117)

Dimensions for mounting holes can be found in the installation instructions available online at [www.shophardinge.com](http://www.shophardinge.com)

# Multiple Collet Block Configurations and Connector Bushing Illustration

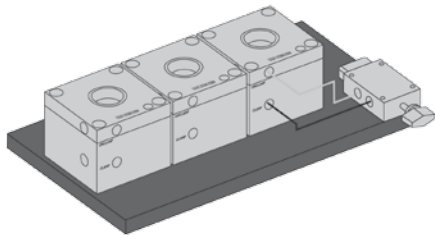

## Multiple Collet Blocks on a Single Subplate

These Hardinge modular collet blocks connect together using internal connector bushings for a compact footprint with no exposed plumbing. Below are examples of linear subplate configurations with space included to mount a valve.

**You could be producing more parts-per-hour.  
What are you waiting for?**

Model	Page	Single	Dual	Triple	Quad
FlexC 42mm Collet Block *	4	11 x 8"	17 <sup>1</sup> / <sub>4</sub> x 8"	23 <sup>1</sup> / <sub>2</sub> x 8"	—
FlexC 65mm Collet Block *	4	12 x 10"	19 <sup>1</sup> / <sub>4</sub> x 10"	26 <sup>1</sup> / <sub>2</sub> x 10"	—
Tri-Grip Collet Block	5	14 x 5 <sup>1</sup> / <sub>2</sub> "	22 <sup>1</sup> / <sub>4</sub> x 5 <sup>1</sup> / <sub>2</sub> "	—	—
5C Dead-Length Low-Pressure Collet Block	9	9 x 6"	13 <sup>1</sup> / <sub>4</sub> x 6"	17 <sup>1</sup> / <sub>2</sub> x 6"	21 <sup>3</sup> / <sub>4</sub> x 6"
16C Dead-Length Low-Pressure Collet Block	9	9 x 6"	13 <sup>1</sup> / <sub>4</sub> x 6"	17 <sup>1</sup> / <sub>2</sub> x 6"	21 <sup>3</sup> / <sub>4</sub> x 6"
5C Pull-Back Collet Block	10	9 x 6"	13 <sup>1</sup> / <sub>4</sub> x 6"	17 <sup>1</sup> / <sub>2</sub> x 6"	21 <sup>3</sup> / <sub>4</sub> x 6"
16C Pull-Back Collet Block	10	12 x 10"	19 <sup>1</sup> / <sub>4</sub> x 10"	26 <sup>1</sup> / <sub>2</sub> x 10"	—

Call for additional custom design and manufacturing solutions – 800-843-8801.

\* Not compatible with connector bushings. Units must be externally plumbed together.

### Connector Bushings for Internal Plumbing

Two connector bushings are used for each face of the collet block that is connected to another collet block.

Note: Connector bushings add space between units. Distance between collet blocks will vary depending on the model. Refer to the note at the bottom of each product page for on-center dimensions.

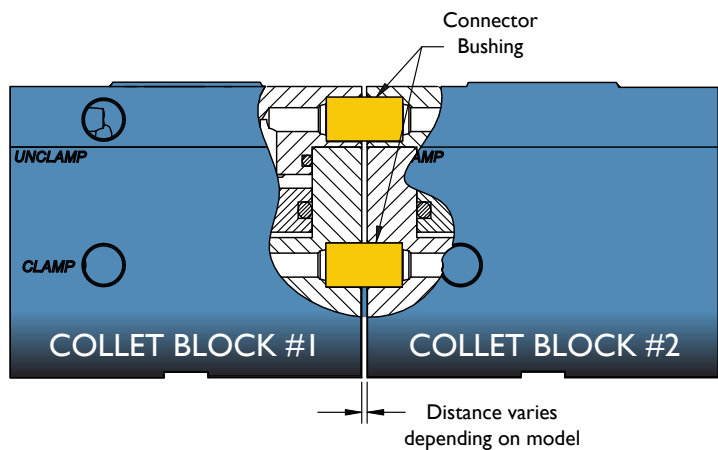

### Connector Bushings

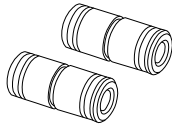

Connector bushings can be used to connect multiple collet blocks to operate on a single control valve. Simply remove the two plugs in the pressure ports of the collet block and insert two connector bushings for each side of the collet block that you would like to connect to another collet block. Connector bushings allow you to maintain consistent air pressure throughout all connected blocks and keep all plumbing internal. See illustration on page 16. Not all units use connector bushings.

Description	For use with	Part Number	(Model No.)
Connector Bushing (1)	5C, 16C and Tri-Grip (used for models on pages 5, 7, 9 and (5C) 10)	7799-00-00-000078	(02-1082)
Connector Bushing (1)	1C collet blocks	7799-00-00-000077	(65-0250)
Connector Bushing (1)	3C collet blocks	7799-00-00-000076	(65-0230)

Note: Connector bushings add space between units. Distance between collet blocks will vary depending on the model. Refer to the note at the bottom of each product page for on-center dimensions.

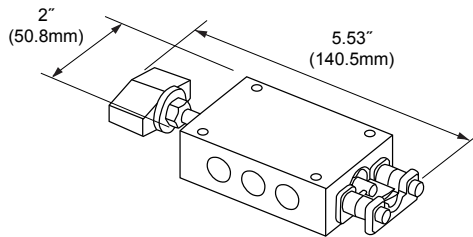

### Pneumatic Control Valve Assembly

Hardinge offers a 2-position, 3-way control valve for simple clamp and unclamp in pneumatic operation. Maximum air pressure is 150 psi.

Description	For use with	Part Number	(Model No.)
2-Position, 3-way Control Valve	Pneumatic operation	7799-00-00-000065	(M3841516)

#### Example of a simple pneumatic configuration

Components include a control valve and three pneumatic collet blocks supplied by Hardinge mounted on a customer machined fixture plate. Two connector bushings are used between each collet block for internal plumbing. A total of four connector bushings would be used in this example. (schematic shown in clamp position)

Dimensions for mounting holes are available on the installation instructions online at [www.shophardinge.com](http://www.shophardinge.com)

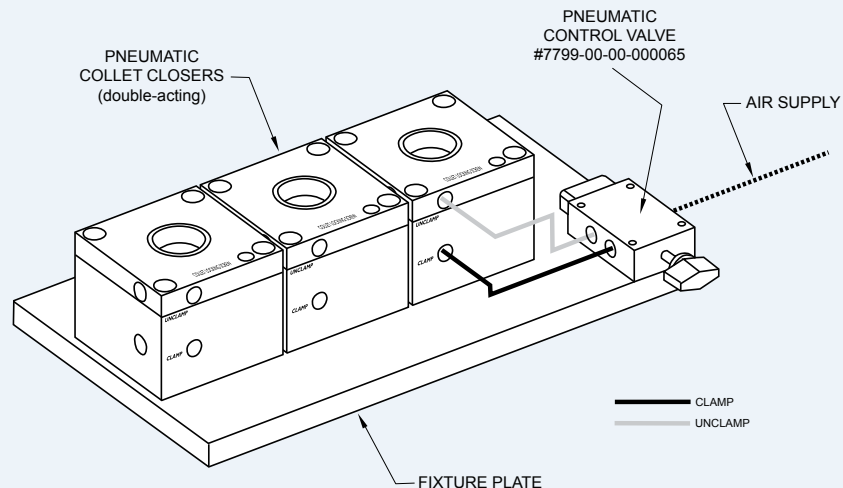

# Collets, FlexC™ Vulcanized Collets, Sure-Grip® Expanding Collets and Collet Wrenches

## Precision-machined Collets

Precision-machined **Collets** are manufactured to exacting standards from special alloy steel. Threads are heat treated and the body is spring tempered to assure accuracy and durability at low cost. All collets are available in fractional sizes of round, hexagon and square to capacity. In addition, many round collets are stocked in metric, decimal, letter and number sizes. Most of the popular sizes of round serrated, taper hole and rectangular collets are available from stock. Refer to brochure 2348 for detailed information.



## Collet Capacities

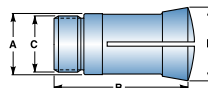

Collet Style	DIMENSIONS				CAPACITY			Collet Wrench Part No.
	A Back Bearing Diameter	B Overall Length	C Thread	D Head Diameter	Round	Hex	Square	
1C	.335" (8.51)	1.438" (36.53)	.322" x 40 RH	.500" (12.70)	1/4" (6.35)	7/32" (5.55)	11/64" (4.37)	7799-85
3C	.650" (16.51)	2.688" (68.28)	.640" x 26 RH	.855" (21.72)	1/2" (12.70)	7/16" (11.11)	11/32" (8.73)	7799-84
5C	1.250" (31.75)	3.281" (83.34)	1.238" x 20 RH <sup>1</sup>	1.470" (37.34)	11/16" (26.99)	29/32" (23.02)	3/4" (19.05)	7799-83
16C	1.889" (47.98)	4.312" (109.52)	1.870" x 1.75mm RH <sup>1</sup>	2.265" (57.53)	15/8" (41.28)	113/32" (35.72)	13/64" (28.97)	7799-82
3J	2.000" (50.80)	3.750" (95.25)	1.988" x 20 RH	2.205" (56.00)	13/4" (44.45)	117/32" (38.89)	11/4" (31.75)	7799-81
22J	2.562" (65.07)	4.000" (101.60)	2.550" x 18 RH	2.780" (70.61)	21/4" (57.15)	115/16" (49.21)	11/16" (39.69)	7799-80
35J	3.875" (98.43)	5.000" (127.00)	3.861" x 18 RH	4.150" (105.41)	31/2" (88.90)	3" (76.20)	27/16" (61.91)	7799-79

<sup>1</sup> - Internal Stop Thread: (5C: 1.041" x 24 RH), (16C: 1.687" x 20TPI RH), (20C: M53 x 1mm RH), (25C: 25/8" x 24TPI RH), (3J: 1.79" x 24TPI RH).

## Precision-machined Step Chucks and Closers

**Step Chucks** are used for accurately holding work up to 6" in diameter. Castings, moldings, stampings and machined parts are held rigidly and accurately. Tubing can be held without crushing or distorting. **Regular-Depth Step Chucks** will grip up to a depth of 1/2". **Extra-Depth Step Chucks** will grip up to a depth of 1 1/4". Step Chuck closers are required. Refer to brochure 2348 for detailed information.

## FlexC™ Vulcanized Collets

Hardinge **FlexC Collets** are available in 42 and 65mm round smooth, round serrated, hexagon serrated, square smooth, emergency and S-master styles. Collets change out in seconds and have a true parallel grip with high grip force to eliminate push back or rotation. FlexC collet blocks can be found on page 4. Refer to brochure 2365 for detailed information. Hardinge FlexC collet systems are also available for lathe spindles.

42mm Compression Wrench - Part No. C-4200000-WREN

65mm Compression Wrench - Part No. C-6500000-WREN

## Sure-Grip® Expanding Collet Systems

Hardinge **Collet-Style Expanding Collet Systems** mount directly into the spindle and instantly locate on center. The Hardinge design provides true parallel gripping with high gripping force even when gripping on half of the collet body. Interchangeable collet heads have a gripping range of +.015 to -.001" (+.38 to -.025mm). Available in 5C and 16C styles for pull-back style collet blocks found on pages 6, 8 and 10. Refer to brochure 2270 for detailed information.





## ***What are the minimum and maximum part sizes that I can grip in a collet block?***

A 1C collet for the 1C collet block can be ordered with a gripping diameter as low as .008" (.2mm). 35J collets have a maximum capacity of 3 1/2" (88.9mm). Select 5C and 16C collet blocks will use a step chuck and closer for larger diameters up to 6" (152.4mm).

## ***What components do I need for a simple pneumatic configuration?***

If you are grouping multiple collet blocks, you will need to mount them on a fixture plate along with a control valve to turn the air on and off. You can use one valve to clamp and unclamp all parts simultaneously or configure multiple valves to control each block or row of blocks independently from others. Select models will plumb together with connector bushings for internal plumbing. Collet block models that don't use connector bushings will have to be plumbed externally. Refer to the schematics on page 16.

A single 5C fail-safe pull-back (page 6) or a single 5C low-pressure (page 8) flange mount collet block can be mounted directly to the t-slot of your machining center and quickly connect to your standard shop air line.

## ***What is the purpose of using the standard manifold with a quick-disconnect handle?***

The standard manifold does NOT allow you to disconnect the fixture from the hydraulics and maintain a clamped position, but it does give you a faster method of removing the fixture from the machining area without having to unscrew each of the lines from a standard control valve.

## ***Can I damage a collet by applying too much draw bar force?***

Yes, you must not exceed a specified input pressure depending on the collet style (5C, 3J, 1C, etc.). Collet threads can be stripped when applying too much pressure. Refer to the chart on page 3 for maximum input pressure.

## ***Why would I need to choose a high-pressure collet block?***

High-pressure collet blocks are recommended for larger diameters, heavy machining, off-center drilling and other high-force machining applications. The part may slip in the collet if you don't have enough gripping pressure for the high-force operation intended.

## ***When do I need to use an accumulator?***

An accumulator is required when using the quick-disconnect handle and manifold with check valve. It serves as a backup reservoir that will maintain hydraulic pressure during the disconnect period to maintain the required clamp position if a leak should occur.

## ***What do I need to buy for a hydraulically-operated collet block fixture or tombstone?***

If you don't already have a hydraulic source at your machine, you would need to purchase a pump along with a 2-position, 4-way control valve. You can use one control valve to clamp and unclamp all parts simultaneously or configure multiple valves to control each block or row of blocks independently from others. The control valve would mount on the fixture along with the collet blocks and connect to the pump outside of your machine. Refer to the schematics on page 13.

A quick-disconnect system is optional. A quick-disconnect handle with standard manifold allows for a quick disconnect, but will not maintain the clamp position when removed from the fixture plate. To maintain the clamped position when removing the disconnect handle, you would use the manifold with a built-in check valve. This option is ideal for preloading pallets. A 3-position, 4-way control valve and an accumulator is required when using the check valve option and the control valve would be mounted outside of the machine. The accumulator is available in a vertical or horizontal mount and will mount on the fixture with the collet blocks. Refer to the schematics on page 13.

## ***How many connector bushings do I need?***

Select collet blocks are connected using two connector bushings per side. If you have one row of four collet blocks, you would need six connector bushings. If you had two rows of two collet blocks, you would need eight connector bushings to plumb all sides together for a continuous loop.

## ***Will my first block have the same pressure as the last block in the row on my fixture plate?***

Yes, equal pressure distribution is maintained throughout the continuous passage made by the connector bushings. You are pressurizing the entire unit and there is no flow involved.

Spindle Tooling for Manual & CNC Lathes

Spindle Tooling for Automatics, Turret Lathes & Rotary Transfer Machines

Swiss-Type Collets, Guide Bushings & Barloader Collets

FlexC™ Vulcanized, Quick-Change Collet Systems

Sure-Grip® Expanding Collet Systems

HCAC® Collet Adaptation Chucks

Sure-Grip® 3-Jaw Power Chucks

Chuck Jaws

Toolholder Collets, Bushings & Tool Holders

Precision CNC Tooling for Mills

Collet Blocks

Rotary Tables and Indexers

Custom Workholding

Industrial Products

Machine Tools

Hardinge manufactures workholding for all brands of lathes, mills, grinding machines, automatic screw machines, rotary transfer machines, turret lathes, automation and assembly. Expect more from your workholding. Choose Hardinge precision and reliability for increased productivity and value!

**Call us today, we've got your answer.**



Hardinge Inc. One Hardinge Drive | P.O. Box 1507 | Elmira, New York 14902-1507 USA

USA: 800-843-8801, or 607-378-4022 | Canada: 800-468-5946 | Fax: 607-734-3886

To Order Online: [www.shophardinge.com](http://www.shophardinge.com) | Corporate Homepage: [www.hardinge.com](http://www.hardinge.com) | E-mail: [info@hardinge.com](mailto:info@hardinge.com)

